



# Full-Black Series

## D6Q II · 345-365W MWT All Black Module Cast-mono Half-cut 63 Cells

### 20.3%

Module efficiency up to 20.3%



### Full Black Series MWT PV Module

- Full Black**  
All black design for more elegant rooftop
- High Efficiency**  
MWT back contact cell and modules with busbar-free design and higher efficiency
- High Reliability**  
Conductive back sheet 2D encapsulation without soldering, resulted lower degradation under multiple extreme testing condition
- Superior Warranty**  
The only single-glass module with 30-year power warranty by LLOYD'S& PICC worldwide
- High ROI**  
Higher return of investment with higher power output
- Lead Free**  
Eco-friendly PV design achieves Lead-free without soldering materials

### Reinsurance Coverage for 30 Years

**12 year**  
Quality  
Warranty

**30 year**  
Performance  
Warranty

Insured by PICC and LLOYD'S

# PICC LLOYD'S

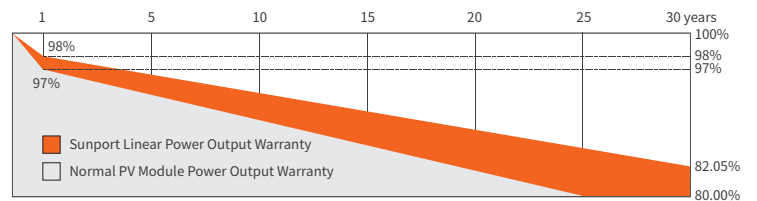

※1st year degradation less than 2%, 30 years linear power output 82% guaranteed.

### Comprehensive Qualifications & Certifications

- ★CQC Top Runner Advanced Technology Certification (4A class)
- ★TUV NORD Certification
- ★ISO 9001: 2015 Quality Management System
- ★ISO 14001: 2015 Environment Management System
- ★ISO 45001: 2018 Occupation Health Safety Management System
- ★TUV NORD Certification



Jiangsu Sunport Power Corp.,Ltd

Add: No.20, Xishi Road, Xinwu District, Wuxi, China 214028

Email: info@sunportpower.com

Web: www.sunportpower.com

## Electrical Characteristics at Standard Test Conditions(STC)

Spec/Model	Unit	SPP345DHEH	SPP350DHEH	SPP355DHEH	SPP360DHEH	SPP365DHEH
Max-Power(Pm)	W	345	350	355	360	365
Power Tolerance	W			0~+5		
Max-Power Voltage(Vm)	V	34.7	34.9	35.1	35.3	35.5
Max-Power Current(I <sub>m</sub> )	A	9.95	10.03	10.12	10.20	10.29
Open-Circuit Voltage(V <sub>oc</sub> )	V	42.0	42.2	42.4	42.6	42.8
Short-Circuit Current(I <sub>sc</sub> )	A	10.47	10.55	10.63	10.72	10.80
Module Efficiency(η <sub>m</sub> )	%	19.2	19.4	19.7	20.0	20.3

STC: AM=1.5, Irradiation 1000W/m<sup>2</sup>, Module Temperature 25°C

## Electrical Characteristics at Nominal Module Operating Temperature (NMOT)

Spec/Model	Unit	SPP345DHEH	SPP350DHEH	SPP355DHEH	SPP360DHEH	SPP365DHEH
Max-Power(Pm)	W	258	262	266	270	274
Max-Power Voltage(Vm)	V	31.9	32.1	32.3	32.5	32.7
Max-Power Current(I <sub>m</sub> )	A	8.09	8.17	8.24	8.31	8.38
Open-Circuit Voltage(V <sub>oc</sub> )	V	39.2	39.4	39.6	39.8	40.0
Short-Circuit Current(I <sub>sc</sub> )	A	8.59	8.66	8.73	8.80	8.86

NMOT: Irradiation 800W/m<sup>2</sup>, ambient temperature 20°C, Wind Speed 1m/s

## Temperature Coefficient

Nominal Module Operating Temperature	43±2°C
Temperature coefficient of P <sub>max</sub>	-0.36%/°C
Temperature coefficient of V <sub>oc</sub>	-0.28%/°C
Temperature coefficient of I <sub>sc</sub>	0.06%/°C

## Package

Transportation	Container Size	Quantity(pcs)	Quantity(per pallet)
Container	40' HC	806/858	31

## Mechanical Characteristics

Dimension(L×W×H)	1772mmx1016mmx35mm
Weight	20kg
Glass Type	High Transmittance Anti-reflective Coated Tempered Glass /3.2mm
Solar Cell	126(6×21) / Cast-mono / 162.75mm (Half-cell)
Encapsulant	EVA
Frame	Anodized Aluminum Alloy / Black
Junction Box	IP67 / IP68
Cable	4mm <sup>2</sup> , 350mm (+) / 150mm (-); Customizable
Connector	MC4 Compatible

## I-V Curve

I-V Curve at different irradiation (SPP360DHEH)

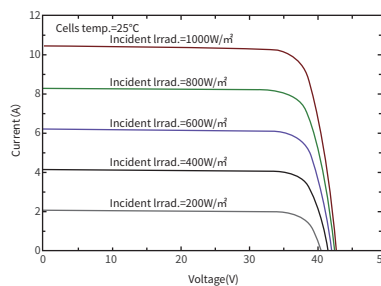

I-V Curve at different irradiation (SPP360DHEH)

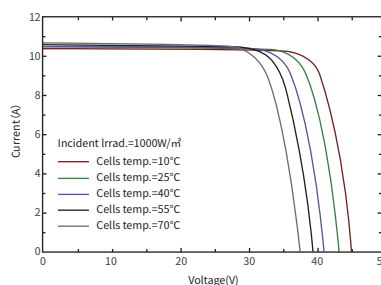

## Module Size

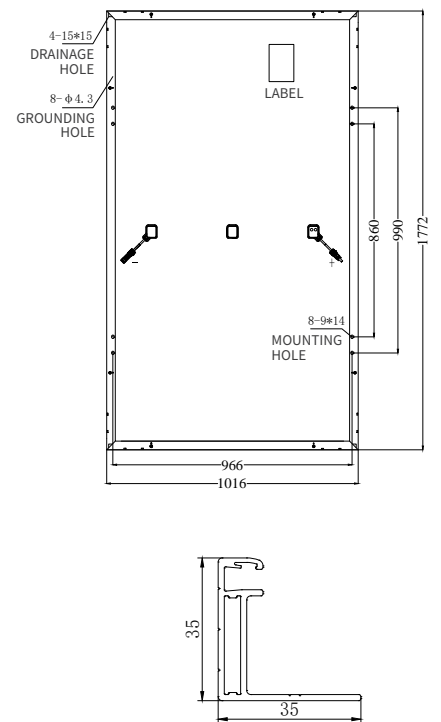

## Operating Conditions

Max System Voltage	1500V(TUV)
Max Fuse Rated Current	15A
Operating Temperature Range	-40°C~+85°C
Mechanical Load	5400Pa (front) /2400Pa (rear)
Max Allowable Hail Load	φ25mm hail, from 1m of distance at 23 m/s
Application Class	Class A